

BLUE STAR Power Systems

Diesel Product Line

208-600 Volt

JD150-01

60 Hz / 1800 RPM

150 kWe

Standby

Ratings

| | 240V | 208V | 240V | 480V | 600V |
|------------------------|--------------|--------------|---------------|--------------|--------------|
| Phase | 1 | 3 | 3 | 3 | 3 |
| PF | 1.0 | 0.8 | 0.8 | 0.8 | 0.8 |
| Hz | 60 | 60 | 60 | 60 | 60 |
| Generator Model | UCDI274J1 | UCI274G | UCI274G | UCI274F | UCI274F |
| Connection | 12 LEAD DD | 12 LEAD WYE | 12 LEAD DELTA | 12 LEAD WYE | 4 LEAD WYE |
| kWe | 150 | 150 | 150 | 150 | 150 |
| AMPS | 625 | 521 | 452 | 226 | 181 |
| Temp Rise | 125°C / 40°C | 125°C / 40°C | 125°C / 40°C | 125°C / 40°C | 125°C / 40°C |

Standard Equipment

Engine

- Radiator Cooled Unit Mounted (50°C)
- Radiator Duct Flange (OPU Only)
- Blower Fan & Fan Drive
- Starter & Alternator
- Oil Pump & Filter
- Oil Drain Extension w/Valve
- Governor - Electronic Isochronous
- 12V Battery System & Cables
- Air Cleaner (Dry Single Stage)
- Critical Grade Silencer Mounted
- Flexible Fuel Connector
- EPA Certified Tier 3

Generator

- Brushless Single Bearing
- Automatic Voltage Regulator
- ± 1% Voltage Regulation
- 4 Pole, Rotating Field
- 125°C Standby Temperature Rise
- 100% of Rated Load - One Step
- 5% Maximum Harmonic Content
- NEMA MG 1, IEEE and ANSI Standards Compliance for Temperature Rise

Additional

- Single Source Supplier
- UL 2200 & cUL Listed
- CSA Certified
- Seismic Certified to IBC 2021
- NFPA 110 / CSA C282 Compliant
- Microprocessor Based Digital Control Panel Mounted in NEMA 12 Enclosure
- Base - Formed Steel
- Main Line Circuit Breaker Mounted & Wired
- Battery Charger 12V 6 Amp
- Jacket Water Heater -20°F 2000W 240V w/Isolation Valves
- Vibration Isolation Mounts
- 2 Year / 2000 Hour Standby Warranty
- Standard Colors - White / Gray

Application Data

Engine

| | | | |
|-----------------------|--------------------|--------------------------------------|---------------------------|
| Manufacturer: | John Deere | Displacement - Cu. In. (lit): | 415 (6.80) |
| Model: | 6068HF285 | Bore - in. (cm) x Stroke - in. (cm): | 4.19 (10.6) x 5.00 (12.7) |
| Type: | 4-Cycle | Compression Ratio: | 19.0:1 |
| Aspiration: | Turbo Charged, CAC | Rated RPM: | 1800 |
| Cylinder Arrangement: | 6 Cylinder Inline | Max HP Stby (kW _m): | 237 (177) |

Exhaust System

Standby

| | |
|---|--------------|
| Gas Temp. (Stack): °F (°C) | 981 (527) |
| Gas Volume at Stack Temp: CFM (m ³ /min) | 1,158 (32.8) |
| Maximum Allowable Exhaust Restriction: in. H ₂ O (kPa) | 30.0 (7.50) |

Cooling System

| | |
|---|--------------|
| Ambient Capacity of Radiator: °F (°C) | 122 (50.0) |
| Maximum Allowable Static Pressure on Rad. Exhaust: in. H ₂ O (kPa) | 0.50 (0.12) |
| Water Pump Flow Rate: GPM (lit/min) | 48.0 (182) |
| Heat Rejection to Coolant: BTUM (kW) | 5,407 (94.6) |
| Heat Rejection to CAC: BTUM (kW) | 1,708 (29.9) |
| Heat Radiated to Ambient: BTUM (kW) | 3,021 (52.9) |

Air Requirements

| | |
|--|--|
| Aspirating: CFM (m ³ /min) | 448 (12.7) |
| Air Flow Required for Rad. Cooled Unit: CFM (m ³ /min) | 10,683 (302) |
| Air Flow Required for Heat Exchanger/Rem. Rad. CFM (m ³ /min) | Consult Factory For Remote Cooled Applications |

Fuel Consumption

| | |
|--|-------------|
| At 100% of Power Rating: gal/hr (lit/hr) | 11.1 (42.0) |
| At 75% of Power Rating: gal/hr (lit/hr) | 8.95 (33.9) |
| At 50% of Power Rating: gal/hr (lit/hr) | 6.72 (25.4) |

Fluids Capacity

| | |
|---|-------------|
| Total Oil System: gal (lit) | 5.02 (19.0) |
| Engine Jacket Water Capacity: gal (lit) | 3.14 (11.9) |
| System Coolant Capacity: gal (lit) | 6.10 (23.1) |

Deration Factors: Rated Power is available up to 10,000 ft (3,048 m) at ambient temperatures to 122°F (50°C). Consult factory for site conditions above these parameters.

DCP7310 Control Panel

Standard Features

- Digital Metering
- Engine Parameters
- Generator Protection Functions
- Engine Protection
- CAN Bus (J1939) ECU Communications
- Windows-Based Software
- Multilingual Capability
- Remote Communications to DSE2548 Remote Annunciator
- 8 Programmable Contact Inputs
- 10 Contact Outputs
- RS485 Communicator Interface
- cULus Listed, CE Approved
- Event Recording
- IP 65 rating (with supplied gasket) offers increased resistance to water ingress
- NFPA 110 Level 1 Compatible



Weights / Dimensions / Sound Data

| | L x W x H | Weight lbs |
|----------------|------------------|------------|
| OPU | 110 x 54 x 64 in | 3,500 |
| Level 1 | 130 x 54 x 74 in | 4,375 |
| Level 2 | 130 x 54 x 74 in | 4,425 |
| Level 3 | 164 x 54 x 74 in | 4,725 |

Please allow 6-12 inches for height of exhaust stack.

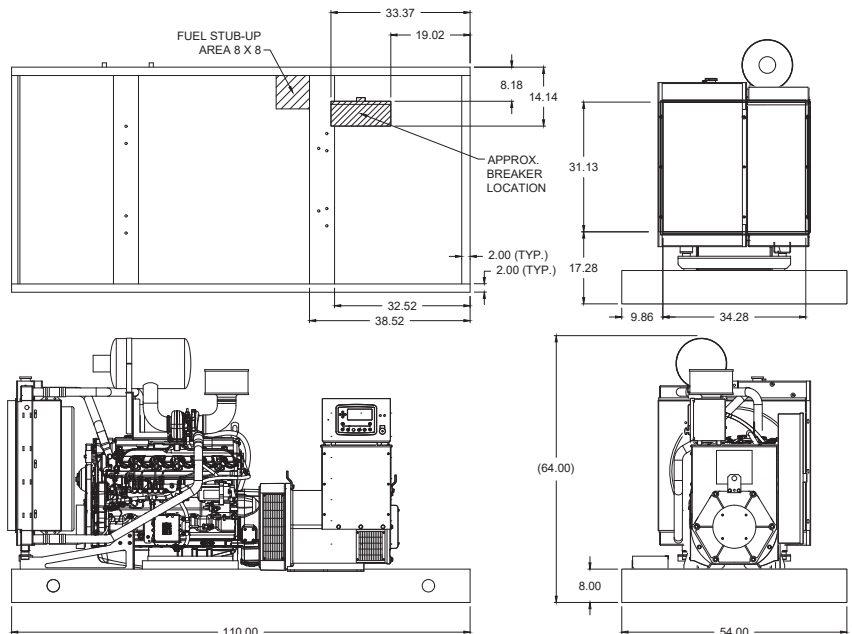

| | No Load | Full Load |
|----------------|---------|-----------|
| OPU | 82 dBA | 85 dBA |
| Level 1 | 80 dBA | 82 dBA |
| Level 2 | 75 dBA | 78 dBA |
| Level 3 | 71 dBA | 73 dBA |

Enclosures & Fuel Tanks

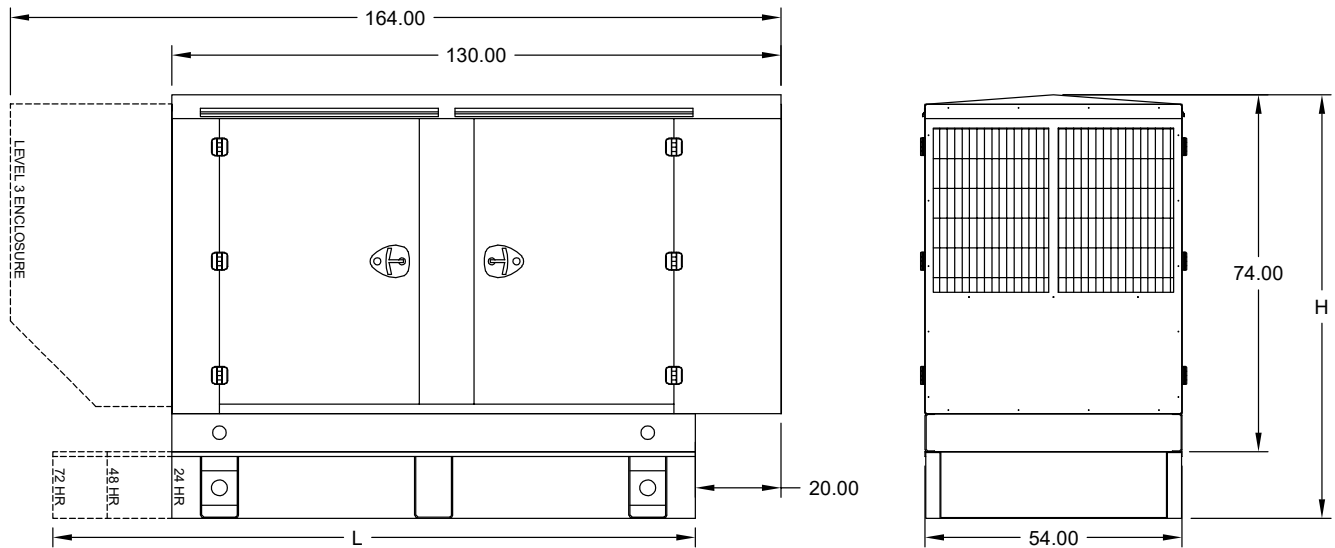

- All enclosure models are 200 MPH wind rating certified in accordance with IBC2021 and ASCE/SEI 7-16 standards.
- Level 2 & 3 enclosures include sound attenuation foam
- Level 3 enclosure includes frontal sound & exhaust hood.
- Enclosure height does not include exhaust stack.

| | 24 Hour 375 Gallon | 48 Hour 750 Gallon | 72 Hour 1125 Gallon |
|----------|-----------------------|-----------------------|------------------------|
| L | 110.00 | 144.00 | 204.00 |
| H | 100.00 | 110.00 | 110.00 |

Notes

- All specification sheet dimensions are represented in inches.
- All drawings based on standard 480 volt standby generator. Lengths may vary with other voltages. All drawings and dimensions subject to change without notice.
- All enclosures and fuel tanks are based on the standard unit configuration. Any requested deviation can change dimensions.
- Sound data is measured at 23 feet (7 meters) in accordance with ISO 8528-10.
- All materials and specifications subject to change without notice.

Blue Star Power Systems

2250 Carlson Drive
North Mankato, Minnesota 56003
Phone + 1 507 345 1776
bluestarps.com
quote.bluestarps.com
sales@bluestarps.com

/ A DEUTZ COMPANY /