

BLUE STAR

Power Systems

Diesel Product Line

208-600 Volt

JD275-02

60 Hz / 1800 RPM

275 kWe

Standby

Ratings

	208V	240V	480V	600V
Phase	3	3	3	3
PF	0.8	0.8	0.8	0.8
Hz	60	60	60	60
Generator Model	S4L1S-D4	S4L1S-D4	S4L1S-D4	S4L1S-D4
Connection	12 LEAD WYE	12 LEAD DELTA	12 LEAD WYE	4 LEAD WYE
kWe	275	275	275	275
AMPS	955	828	414	331
Temp Rise	125°C / 40°C	125°C / 40°C	125°C / 40°C	125°C / 40°C

Standard Equipment

- | | | |
|---|---|--|
| <p>Engine</p> <ul style="list-style-type: none"> - Radiator Cooled Unit Mounted (50°C) - Radiator Duct Flange (OPU Only) - Blower Fan & Fan Drive - Starter & Alternator - Oil Pump & Filter - Oil Drain Extension w/Valve - Governor - Electronic Isochronous - 12V Battery System & Cables - Air Cleaner (Dry Single Stage) - Critical Grade Silencer Mounted - Flexible Fuel Connector - EPA Certified Tier 3 | <p>Generator</p> <ul style="list-style-type: none"> - Brushless Single Bearing - Automatic Voltage Regulator - ± 0.50% Voltage Regulation - 4 Pole, Rotating Field - 125°C Standby Temperature Rise - 100% of Rated Load - One Step - 5% Maximum Harmonic Content - NEMA MG 1, IEEE and ANSI Standards Compliance for Temperature Rise | <p>Additional</p> <ul style="list-style-type: none"> - Single Source Supplier - UL 2200 & cUL Listed - CSA Certified - Seismic Certified to IBC 2021 - NFPA 110 / CSA C282 Compliant - Microprocessor Based Digital Control Panel Mounted in NEMA 12 Enclosure - Base - Formed Steel - Main Line Circuit Breaker Mounted & Wired - Battery Charger 12V 6 Amp - Jacket Water Heater -20°F 2500W 240V w/Isolation Valves - Vibration Isolation Mounts - 2 Year / 2000 Hour Standby Warranty - Standard Colors - White / Gray |
|---|---|--|

Application Data

Engine

Manufacturer:	John Deere	Displacement - Cu. In. (lit):	549 (9.00)
Model:	6090HF484	Bore - in. (cm) x Stroke - in. (cm):	4.66 (11.8) x 5.35 (13.6)
Type:	4-Cycle	Compression Ratio:	16.0:1
Aspiration:	Turbo Charged, CAC	Rated RPM:	1800
Cylinder Arrangement:	6 Cylinder Inline	Max HP Stby (kWm):	422 (315)

Exhaust System

Standby

Gas Temp. (Stack): °F (°C)	1,180 (638)
Gas Volume at Stack Temp: CFM (m³/min)	2,084 (59.0)
Maximum Allowable Exhaust Restriction: in. H ₂ O (kPa)	30.0 (7.50)

Cooling System

Ambient Capacity of Radiator: °F (°C)	122 (50.0)
Maximum Allowable Static Pressure on Rad. Exhaust: in. H ₂ O (kPa)	0.50 (0.12)
Water Pump Flow Rate: GPM (lit/min)	74.0 (280)
Heat Rejection to Coolant: BTUM (kW)	5,920 (104)
Heat Rejection to CAC: BTUM (kW)	5,009 (87.7)
Heat Radiated to Ambient: BTUM (kW)	5,434 (95.1)

Air Requirements

Aspirating: CFM (m³/min)	901 (25.5)
Air Flow Required for Rad. Cooled Unit: CFM (m³/min)	15,333 (434)
Air Flow Required for Heat Exchanger/Rem. Rad. CFM (m³/min)	Consult Factory For Remote Cooled Applications

Fuel Consumption

At 100% of Power Rating: gal/hr (lit/hr)	18.7 (70.8)
At 75% of Power Rating: gal/hr (lit/hr)	16.3 (61.7)
At 50% of Power Rating: gal/hr (lit/hr)	11.7 (44.3)

Fluids Capacity

Total Oil System: gal (lit)	8.20 (31.0)
Engine Jacket Water Capacity: gal (lit)	4.25 (16.0)
System Coolant Capacity: gal (lit)	13.2 (50.0)

Deration Factors: Rated Power is available up to 1,677 ft (511 m) at ambient temperatures to 122°F (50°C). Consult factory for site conditions above these parameters.

DCP7310 Control Panel

Standard Features

- Digital Metering
- Engine Parameters
- Generator Protection Functions
- Engine Protection
- CAN Bus (J1939) ECU Communications
- Windows-Based Software
- Multilingual Capability
- Remote Communications to DSE2548 Remote Annunciator
- 8 Programmable Contact Inputs
- 10 Contact Outputs
- RS485 Communicator Interface
- cULus Listed, CE Approved
- Event Recording
- IP 65 rating (with supplied gasket) offers increased resistance to water ingress
- NFPA 110 Level 1 Compatible



Weights / Dimensions / Sound Data

	L x W x H	Weight lbs
OPU	120 x 66 x 79 in	5,475
Level 1	156 x 66 x 94 in	6,700
Level 2	156 x 66 x 94 in	6,775
Level 3	196 x 66 x 94 in	7,125

Please allow 6-12 inches for height of exhaust stack.

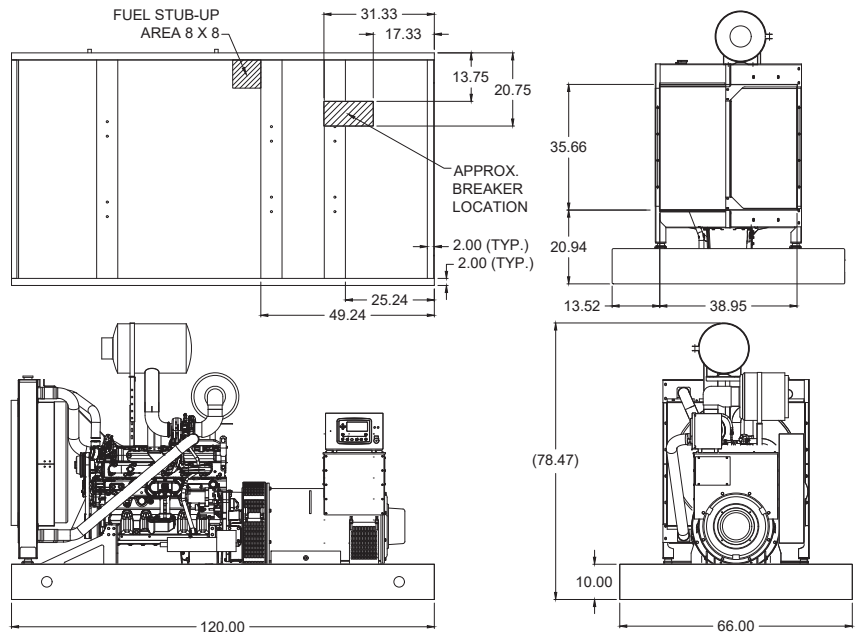

	No Load	Full Load
OPU	84 dBA	86 dBA
Level 1	80 dBA	82 dBA
Level 2	75 dBA	77 dBA
Level 3	69 dBA	71 dBA

Enclosures & Fuel Tanks

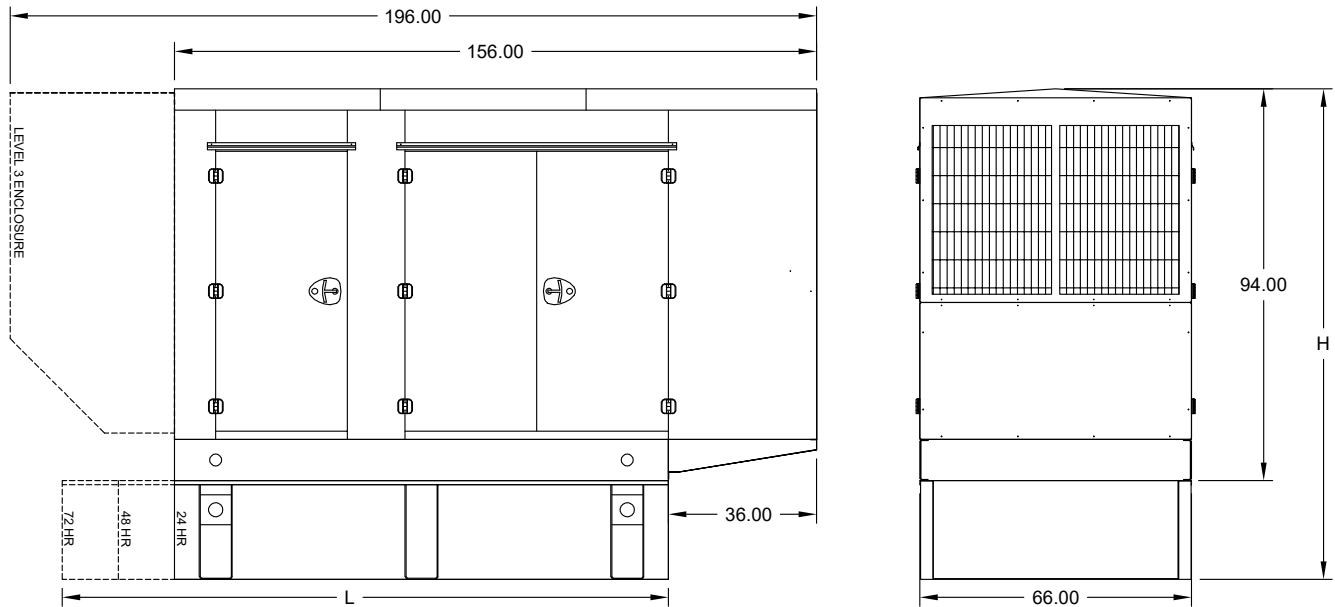

- All enclosure models are 200 MPH wind rating certified in accordance with IBC2021 and ASCE/SEI 7-16 standards.
- Level 2 & 3 enclosures include sound attenuation foam
- Level 3 enclosure includes frontal sound & exhaust hood.
- Enclosure height does not include exhaust stack.

	24 Hour 540 Gallon	48 Hour 1080 Gallon	72 Hour 1620 Gallon
L	120.00	162.00	228.00
H	118.00	130.00	130.00

Notes

- All specification sheet dimensions are represented in inches.
- All drawings based on standard 480 volt standby generator. Lengths may vary with other voltages. All drawings and dimensions subject to change without notice.
- All enclosures and fuel tanks are based on the standard unit configuration. Any requested deviation can change dimensions.
- Sound data is measured at 23 feet (7 meters) in accordance with ISO 8528-10.
- All materials and specifications subject to change without notice.

Blue Star Power Systems

2250 Carlson Drive
North Mankato, Minnesota 56003
Phone + 1 507 345 1776
bluestarps.com
quote.bluestarps.com
sales@bluestarps.com

/ A DEUTZ COMPANY /