

BLUE STAR

Power Systems

Diesel Product Line

208-600 Volt

JD50-03

60 Hz / 1800 RPM

50 kWe

Standby

Ratings

	240V	208V	240V	480V	600V
Phase	1	3	3	3	3
PF	1.0	0.8	0.8	0.8	0.8
Hz	60	60	60	60	60
Generator Model	UCI224F	UCI224E	UCI224E	UCI224D	UCI224D
Connection	12 LEAD DD	12 LEAD WYE	12 LEAD DELTA	12 LEAD WYE	4 LEAD WYE
kWe	50	50	50	50	50
AMPS	208	174	151	75	60
Temp Rise	125°C / 40°C	125°C / 40°C	125°C / 40°C	125°C / 40°C	125°C / 40°C

Standard Equipment

- | | | |
|---|--|---|
| <p>Engine</p> <ul style="list-style-type: none"> - Radiator Cooled Unit Mounted (50°C) - Radiator Duct Flange (OPU Only) - Blower Fan & Fan Drive - Starter & Alternator - Oil Pump & Filter - Oil Drain Extension w/Valve - Governor - Electronic Isochronous - 12V Battery System & Cables - Air Cleaner (Dry Single Stage) - Critical Grade Silencer Mounted - Flexible Fuel Connector - EPA Certified Tier 3 | <p>Generator</p> <ul style="list-style-type: none"> - Brushless Single Bearing - Automatic Voltage Regulator - ± 1% Voltage Regulation - 4 Pole, Rotating Field - 125°C Standby Temperature Rise - 100% of Rated Load - One Step - 5% Maximum Harmonic Content - NEMA MG 1, IEEE and ANSI Standards Compliance for Temperature Rise | <p>Additional</p> <ul style="list-style-type: none"> - Single Source Supplier - UL 2200 & cUL Listed - CSA Certified - Seismic Certified to IBC 2021 - NFPA 110 / CSA C282 Compliant - Microprocessor Based Digital Control Panel Mounted in NEMA 12 Enclosure - Base - Formed Steel - Main Line Circuit Breaker Mounted & Wired - Battery Charger 12V 6 Amp - Jacket Water Heater -20°F 1500W 120V w/Isolation Valves - Vibration Isolation Mounts - 2 Year / 2000 Hours Standby Warranty - Standard Colors - White / Gray |
|---|--|---|

Application Data

Engine

Manufacturer:	John Deere	Displacement - Cu. In. (lit):	275 (4.50)
Model:	4045TF280	Bore - in. (cm) x Stroke - in. (cm):	4.19 (10.6) x 5.00 (12.7)
Type:	4-Cycle	Compression Ratio:	19.0:1
Aspiration:	Turbo Charged	Rated RPM:	1800
Cylinder Arrangement:	4 Cylinder Inline	Max HP Stby (kWm):	75.0 (56.0)

Exhaust System

Standby

Gas Temp. (Stack): °F (°C)	945 (507)
Gas Volume at Stack Temp: CFM (m³/min)	448 (12.7)
Maximum Allowable Exhaust Restriction: in. H ₂ O (kPa)	30.0 (7.50)

Cooling System

Ambient Capacity of Radiator: °F (°C)	122 (50.0)
Maximum Allowable Static Pressure on Rad. Exhaust: in. H ₂ O (kPa)	0.50 (0.12)
Water Pump Flow Rate: GPM (lit/min)	38.0 (144)
Heat Rejection to Coolant: BTUM (kW)	1,821 (31.9)
Heat Radiated to Ambient: BTUM (kW)	1,038 (18.2)

Air Requirements

Aspirating: CFM (m³/min)	180 (5.09)
Air Flow Required for Rad. Cooled Unit: CFM (m³/min)	4,760 (135)
Air Flow Required for Heat Exchanger/Rem. Rad. CFM (m³/min)	Consult Factory For Remote Cooled Applications

Fuel Consumption

At 100% of Power Rating: gal/hr (lit/hr)	4.23 (16.0)
At 75% of Power Rating: gal/hr (lit/hr)	3.37 (12.8)
At 50% of Power Rating: gal/hr (lit/hr)	2.32 (8.78)

Fluids Capacity

Total Oil System: gal (lit)	3.88 (14.7)
Engine Jacket Water Capacity: gal (lit)	2.25 (8.52)
System Coolant Capacity: gal (lit)	5.38 (20.4)

Deration Factors: Rated Power is available up to 10,000 ft (3,048 m) at ambient temperatures to 122°F (50°C). Consult factory for site conditions above these parameters.

DCP7310 Control Panel

Standard Features

- Digital Metering
- Engine Parameters
- Generator Protection Functions
- Engine Protection
- CAN Bus (J1939) ECU Communications
- Windows-Based Software
- Multilingual Capability
- Remote Communications to DSE2548 Remote Annunciator
- 8 Programmable Contact Inputs
- 10 Contact Outputs
- RS485 Communicator Interface
- cULus Listed, CE Approved
- Event Recording
- IP 65 rating (with supplied gasket) offers increased resistance to water ingress
- NFPA 110 Level 1 Compatible



Weights / Dimensions / Sound Data

	L x W x H	Weight lbs
OPU	80 x 38 x 58 in	2,125
Level 1	90 x 38 x 60 in	2,625
Level 2	90 x 38 x 60 in	2,675
Level 3	120 x 38 x 60 in	2,825

Please allow 6-12 inches for height of exhaust stack.

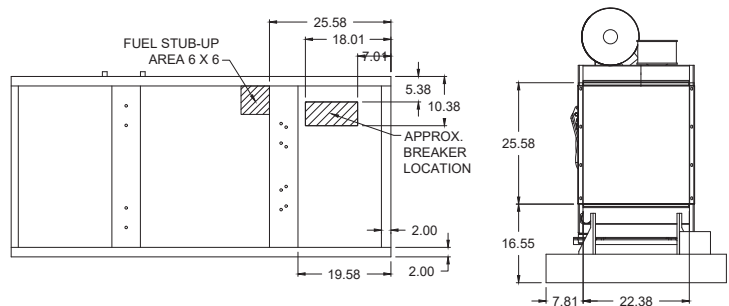

	No Load	Full Load
OPU	73 dBA	77 dBA
Level 1	71 dBA	73 dBA
Level 2	68 dBA	70 dBA
Level 3	63 dBA	65 dBA

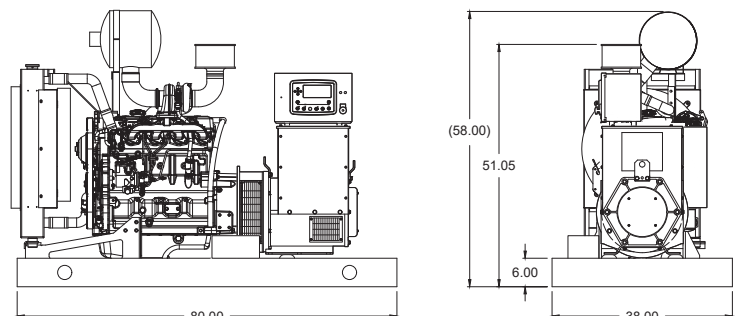

Enclosures & Fuel Tanks

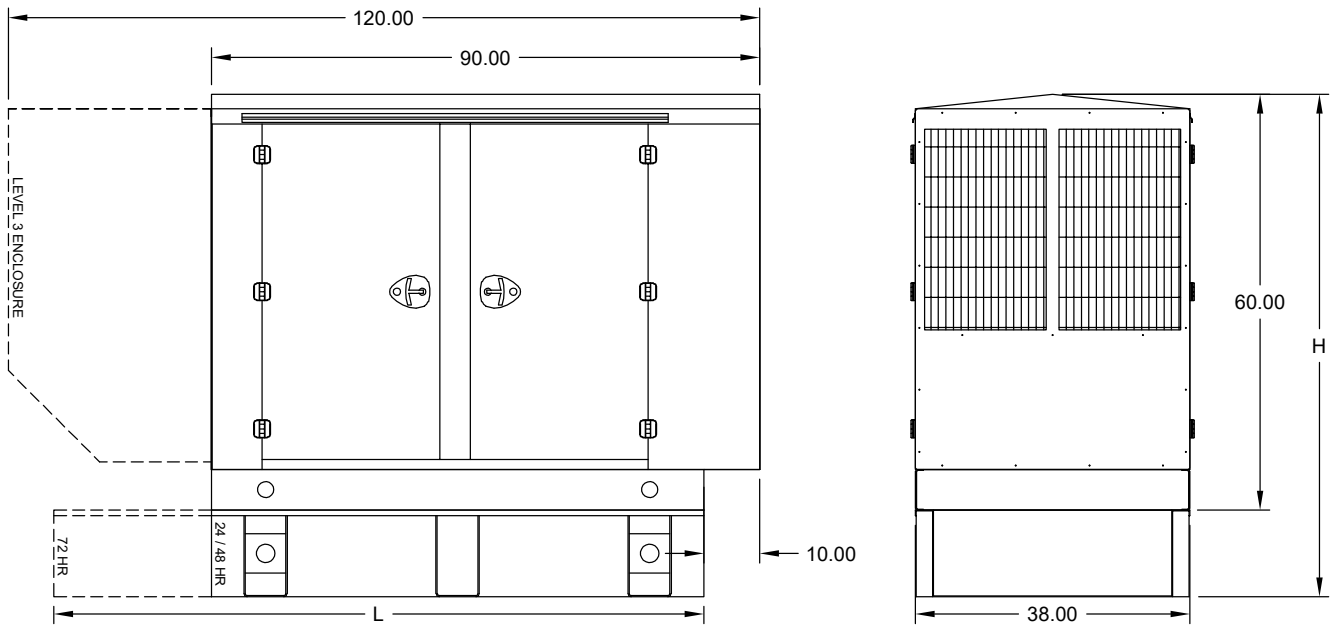

- All enclosure models are 200 MPH wind rating certified in accordance with IBC2021 and ASCE/SEI 7-16 standards.
- Level 2 & 3 enclosures include sound attenuation foam
- Level 3 enclosure includes frontal sound & exhaust hood.
- Enclosure height does not include exhaust stack.

	24 Hour 120 Gallon	48 Hour 240 Gallon	72 Hour 360 Gallon
L	80.00	80.00	108.00
H	80.00	96.00	96.00

Notes

- All specification sheet dimensions are represented in inches.
- All drawings based on standard 480 volt standby generator. Lengths may vary with other voltages. All drawings and dimensions subject to change without notice.
- All enclosures and fuel tanks are based on the standard unit configuration. Any requested deviation can change dimensions.
- Sound data is measured at 23 feet (7 meters) in accordance with ISO 8528-10.
- All materials and specifications subject to change without notice.

Blue Star Power Systems

2250 Carlson Drive
North Mankato, Minnesota 56003
Phone + 1 507 345 1776
bluestarps.com
quote.bluestarps.com
sales@bluestarps.com

/ A DEUTZ COMPANY /