

BLUE STAR

Power Systems

Diesel Product Line

208-600 Volt

VD300-01

60 Hz / 1800 RPM

300 kWe

Standby

Ratings

	208V	240V	480V	600V
Phase	3	3	3	3
PF	0.8	0.8	0.8	0.8
Hz	60	60	60	60
Generator Model	S4L1D-E41	S4L1D-E41	S4L1D-D41	S4L1S-D4
Connection	12 LEAD WYE	12 LEAD DELTA	12 LEAD WYE	4 LEAD WYE
kWe	300	300	300	300
AMPS	1042	903	452	361
Temp Rise	125°C / 40°C	125°C / 40°C	125°C / 40°C	125°C / 40°C

Standard Equipment

Engine

- Radiator Cooled Unit Mounted (55°C)
- Radiator Duct Flange (OPU Only)
- Blower Fan & Fan Drive
- Starter & Alternator
- Oil Pump & Filter
- Oil Drain Extension w/Valve
- Governor - Electronic Isochronous
- 24V Battery System & Cables
- Air Cleaner (Dry Single Stage)
- Critical Grade Silencer Mounted
- Flexible Fuel Connector
- EPA Certified Tier 3

Generator

- Brushless Single Bearing
- Automatic Voltage Regulator
- ± 0.50% Voltage Regulation
- 4 Pole, Rotating Field
- 125°C Standby Temperature Rise
- 100% of Rated Load - One Step
- 5% Maximum Harmonic Content
- NEMA MG 1, IEEE and ANSI Standards Compliance for Temperature Rise

Additional

- Single Source Supplier
- UL 2200 & cUL Listed
- CSA Certified
- Seismic Certified to IBC 2021
- NFPA 110 / CSA C282 Compliant
- Microprocessor Based Digital Control Panel Mounted in NEMA 12 Enclosure
- Base - Formed Steel
- Main Line Circuit Breaker Mounted & Wired
- Battery Charger 24V 5 Amp
- Jacket Water Heater -20°F 4000W 240V w/Isolation Valves
- Vibration Isolation Mounts
- 2 Year / 2000 Hour Standby Warranty
- Standard Colors - White / Gray

Application Data

Engine

Manufacturer:	Volvo Penta	Displacement - Cu. In. (lit):	780 (12.8)
Model:	TAD1351GE	Bore - in. (cm) x Stroke - in. (cm):	5.16 (13.1) x 6.22 (15.8)
Type:	4-Cycle	Compression Ratio:	18.1:1
Aspiration:	Turbo Charged, CAC	Rated RPM:	1800
Cylinder Arrangement:	6 Cylinder Inline	Max HP Stby (kWm):	456 (335)

Exhaust System

Standby

Gas Temp. (Stack): °F (°C)	869 (465)
Gas Volume at Stack Temp: CFM (m³/min)	2,129 (60.3)
Maximum Allowable Exhaust Restriction: in. H ₂ O (kPa)	41.6 (10.4)

Cooling System

Ambient Capacity of Radiator: °F (°C)	131 (55.0)
Maximum Allowable Static Pressure on Rad. Exhaust: in. H ₂ O (kPa)	0.50 (0.12)
Water Pump Flow Rate: GPM (lit/min)	87.0 (329)
Heat Rejection to Coolant: BTUM (kW)	8,872 (156)
Heat Rejection to CAC: BTUM (kW)	4,663 (82.0)
Heat Radiated to Ambient: BTUM (kW)	6,035 (106)

Air Requirements

Aspirating: CFM (m³/min)	908 (25.7)
Air Flow Required for Rad. Cooled Unit: CFM (m³/min)	11,661 (330)
Air Flow Required for Heat Exchanger/Rem. Rad. CFM (m³/min)	Consult Factory For Remote Cooled Applications

Fuel Consumption

At 100% of Power Rating: gal/hr (lit/hr)	21.4 (81.0)
At 75% of Power Rating: gal/hr (lit/hr)	16.4 (62.2)
At 50% of Power Rating: gal/hr (lit/hr)	11.7 (44.2)

Fluids Capacity

Total Oil System: gal (lit)	9.50 (36.0)
Engine Jacket Water Capacity: gal (lit)	5.28 (20.0)
System Coolant Capacity: gal (lit)	11.6 (44.0)

Deration Factors: Rated Power is available up to 6,560 ft (2,000 m) at ambient temperatures to 122°F (50°C). Consult factory for site conditions above these parameters.

DCP7310 Control Panel

Standard Features

- Digital Metering
- Engine Parameters
- Generator Protection Functions
- Engine Protection
- CAN Bus (J1939) ECU Communications
- Windows-Based Software
- Multilingual Capability
- Remote Communications to DSE2548 Remote Annunciator
- 8 Programmable Contact Inputs
- 10 Contact Outputs
- RS485 Communicator Interface
- cULus Listed, CE Approved
- Event Recording
- IP 65 rating (with supplied gasket) offers increased resistance to water ingress
- NFPA 110 Level 1 Compatible



Weights / Dimensions / Sound Data

	L x W x H	Weight lbs
OPU	120 x 66 x 80 in	7,775
Level 1	156 x 66 x 94 in	9,025
Level 2	156 x 66 x 94 in	9,100
Level 3	196 x 66 x 94 in	9,400

Please allow 6-12 inches for height of exhaust stack.

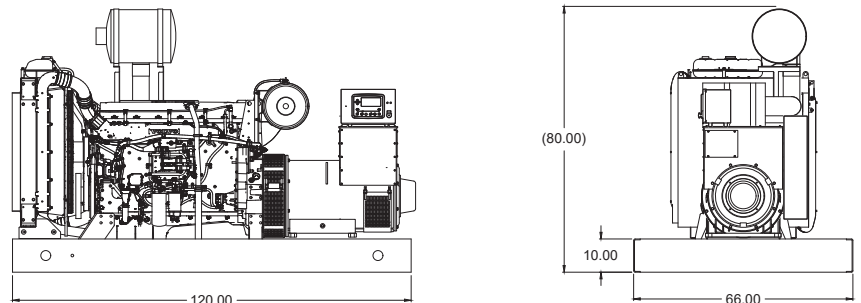
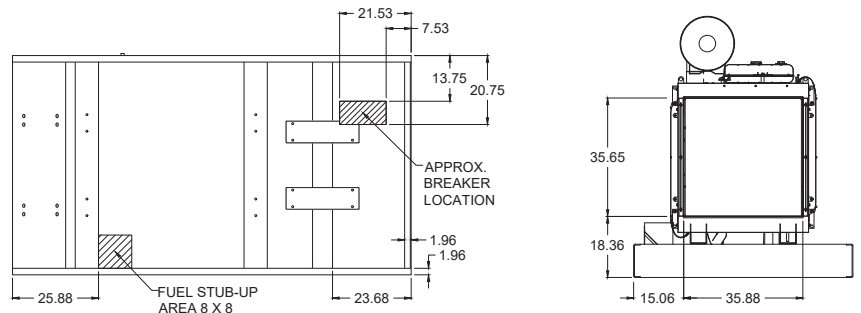

	No Load	Full Load
OPU	86 dBA	88 dBA
Level 1	83 dBA	85 dBA
Level 2	77 dBA	79 dBA
Level 3	69 dBA	71 dBA

Enclosures & Fuel Tanks

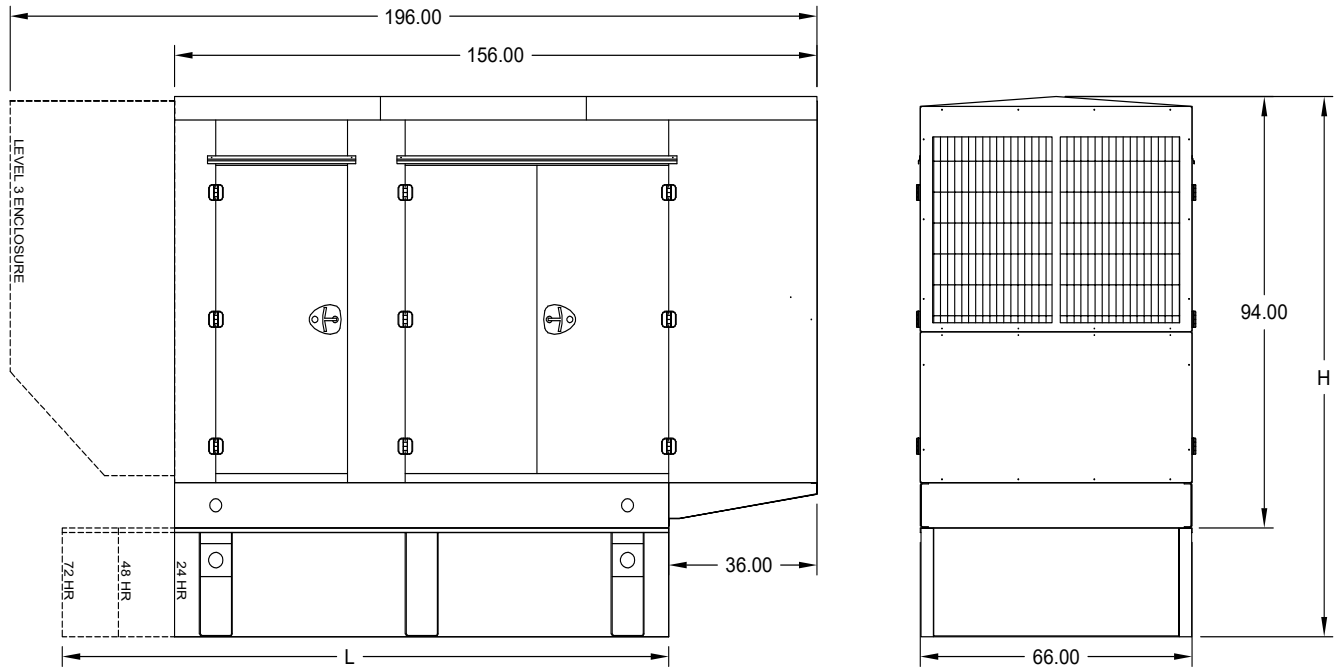

- All enclosure models are 200 MPH wind rating certified in accordance with IBC2021 and ASCE/SEI 7-16 standards.
- Level 2 & 3 enclosures include sound attenuation foam
- Level 3 enclosure includes frontal sound & exhaust hood.
- Enclosure height does not include exhaust stack.

	24 Hour 540 Gallon	48 Hour 1080 Gallon	72 Hour 1620 Gallon
L	120.00	162.00	228.00
H	118.00	130.00	130.00

Notes

- All specification sheet dimensions are represented in inches.
- All drawings based on standard 480 volt standby generator. Lengths may vary with other voltages. All drawings and dimensions subject to change without notice.
- All enclosures and fuel tanks are based on the standard unit configuration. Any requested deviation can change dimensions.
- Sound data is measured at 23 feet (7 meters) in accordance with ISO 8528-10.
- All materials and specifications subject to change without notice.

Blue Star Power Systems

2250 Carlson Drive
North Mankato, Minnesota 56003
Phone + 1 507 345 1776
bluestarps.com
quote.bluestarps.com
sales@bluestarps.com

/ A DEUTZ COMPANY /