

BLUE STAR

Power Systems

Diesel Product Line

208-600 Volt

VD550-04FT4

60 Hz / 1800 RPM

550 kWe / 500 kWe

Standby / Prime

Ratings

	208V	240V	480V	600V
Phase	3	3	3	3
PF	0.8	0.8	0.8	0.8
Hz	60	60	60	60
Generator Model	HCI534F	HCI534F	HCI534E	HCI534E
Connection	12 LEAD WYE	12 LEAD DELTA	12 LEAD WYE	4 LEAD WYE
Standby kWe	550	550	550	550
AMPS	1911	1656	828	662
Temp Rise	125°C / 40°C	125°C / 40°C	125°C / 40°C	125°C / 40°C
Prime kWe	500	500	500	500
AMPS	1737	1505	753	602
Temp Rise	105°C / 40°C	105°C / 40°C	105°C / 40°C	105°C / 40°C

Standard Equipment

Engine	Generator	Additional
<ul style="list-style-type: none"> - Radiator Cooled Unit Mounted (55°C) - Radiator Duct Flange (OPU Only) - Blower Fan & Fan Drive - Starter & Alternator - Oil Pump & Filter - Oil Drain Extension w/Valve - Governor - Electronic Isochronous - 24V Battery System & Cables - Air Cleaner (Dry Single Stage) - SRC Catalyst / Silencer Mounted - Flexible Fuel Connector - EPA Certified Tier 4 Final / EU Stage 5 Certified 	<ul style="list-style-type: none"> - Brushless Single Bearing - Automatic Voltage Regulator - ± 0.50% Voltage Regulation - 4 Pole, Rotating Field - 125°C Standby Temperature Rise - 105°C Prime Temperature Rise - 100% of Rated Load - One Step - 5% Maximum Harmonic Content - NEMA MG 1, IEEE and ANSI Standards Compliance for Temperature Rise 	<ul style="list-style-type: none"> - Single Source Supplier - UL 2200 & cUL Listed - CSA Certified - Seismic Certified to IBC 2021 - NFPA 110 / CSA C282 Compliant - Microprocessor Based Digital Control Panel Mounted in NEMA 12 Enclosure - Base - Structural Steel - Main Line Circuit Breaker Mounted & Wired - Battery Charger 24V 5 Amp - Jacket Water Heater -20°F 5000W 240V w/Isolation Valves - Vibration Isolation Mounts - 2 Year / 2000 Hour Standby Warranty - 1 Year / 1500 Hour Prime Warranty - Standard Colors - White / Gray

Application Data

Engine

Manufacturer:	Volvo Penta	Displacement - Cu. In. (lit):	984 (16.12)
Model:	TWD1682GE	Bore - in. (cm) x Stroke - in. (cm):	5.67 (14.4) x 6.50 (16.5)
Type:	4-Cycle	Compression Ratio:	16.8:1
Aspiration:	Turbo Charged, H ₂ O to Air CAC	Rated RPM:	1800
Cylinder Arrangement:	6 Cylinder Inline	Max HP Stby (kWm):	850 (634)

Exhaust System

	Standby	Prime
Gas Temp. (Stack): °F (°C)	826 (441)	788 (420)
Gas Volume at Stack Temp: CFM (m ³ /min)	4,347 (123)	4,025 (114)
Maximum Allowable Exhaust Restriction: in. H ₂ O (kPa)	40.0 (10.0)	44.0 (11.0)

Cooling System

Ambient Capacity of Radiator: °F (°C)	131 (55.0)	131 (55.0)
Maximum Allowable Static Pressure on Rad. Exhaust: in. H ₂ O (kPa)	0.50 (0.12)	0.50 (0.12)
Water Pump Flow Rate: GPM (lit/min)	125 (473)	125 (473)
Heat Rejection to Coolant: BTUM (kW)	11,886 (209)	10,857 (190)
Heat Rejection to CAC: BTUM (kW)	8,473 (149)	7,771 (136)
Heat Radiated to Ambient: BTUM (kW)	11,475 (201)	10,490 (184)

Air Requirements

Aspirating: CFM (m ³ /min)	1,667 (47)	1,584 (45)
Air Flow Required for Rad. Cooled Unit: CFM (m ³ /min)	27,122 (768)	27,122 (768)
Air Flow Required for Heat Exchanger/Rem. Rad. CFM (m ³ /min)	Consult Factory For Remote Cooled Applications	

Fuel Consumption

At 100% of Power Rating: gal/hr (lit/hr)	38.3 (145.0)	34.3 (130.0)
At 75% of Power Rating: gal/hr (lit/hr)	29.1 (110.0)	25.9 (98.0)
At 50% of Power Rating: gal/hr (lit/hr)	20.6 (78.0)	19.0 (72.0)
DEF Consumption (% of fuel consumption)	± 6.60%	± 6.60%

Fluids Capacity

Total Oil System: gal (lit)	12.7 (48.0)	12.7 (48.0)
Engine Jacket Water Capacity: gal (lit)	6.60 (25.0)	6.60 (25.0)
System Coolant Capacity: gal (lit)	23.8 (90.1)	23.8 (90.1)
DEF Tank Capacity: gal (lit)	52.8 (200.0)	52.8 (200.0)

Deration Factors: Rated Power is available up to 4,921 Ft (1500m) at ambient temperatures to 122°F (50°C). Consult factory for site conditions above these parameters.

DCP7310 Control Panel

Standard Features

- Digital Metering
- Engine Parameters
- Generator Protection Functions
- Engine Protection
- CAN Bus (J1939) ECU Communications
- Windows-Based Software
- Multilingual Capability
- Remote Communications to DSE2548 Remote Annunciator
- 8 Programmable Contact Inputs
- 10 Contact Outputs
- RS485 Communicator Interface
- cULus Listed, CE Approved
- Event Recording
- IP 65 rating (with supplied gasket) offers increased resistance to water ingress
- NFPA 110 Level 1 Compatible

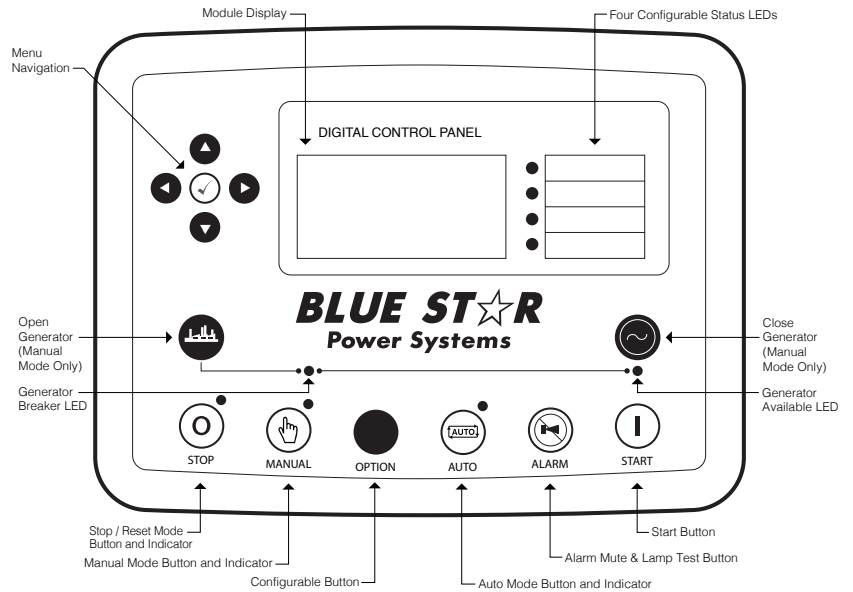

Weights / Dimensions / Sound Data

	L x W x H	Weight lbs
OPU	160 x 84 x 118 in	13,100
Level 1	198 x 84 x 122 in	15,025
Level 2	198 x 84 x 122 in	15,100
Level 3	252 x 84 x 122 in	15,750

Please allow 6-12 inches for height of exhaust stack.

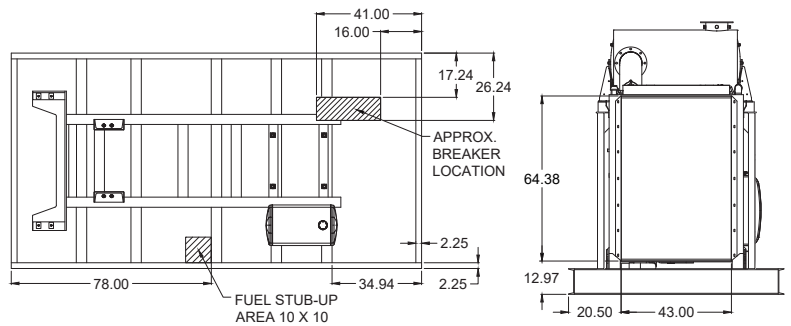

	No Load	Full Load
OPU	90 dBA	93 dBA
Level 1	85 dBA	88 dBA
Level 2	81 dBA	83 dBA
Level 3	73 dBA	75 dBA

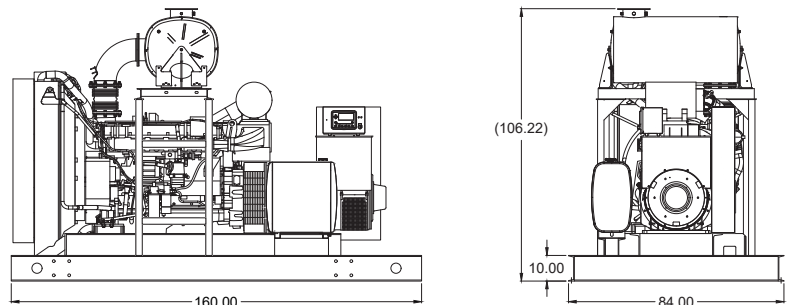

Enclosures & Fuel Tanks

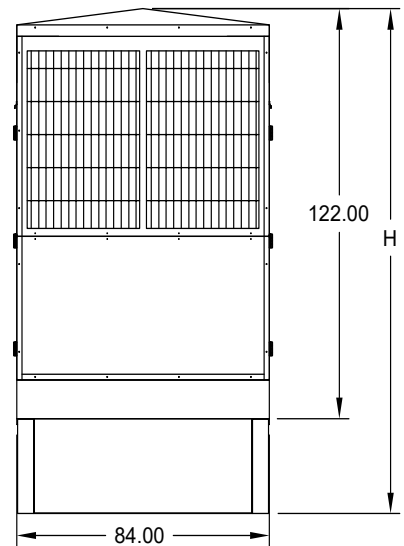
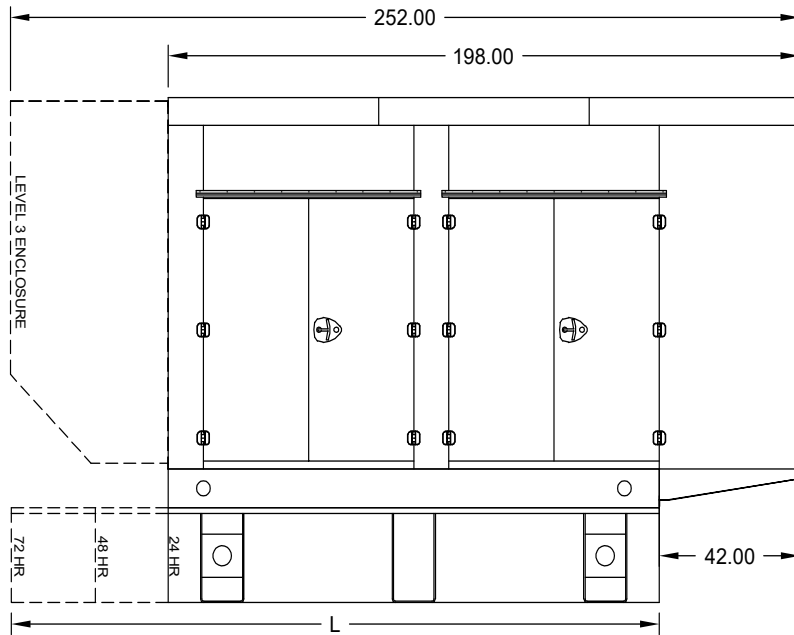

- All enclosure models are 200 MPH wind rating certified in accordance with IBC2021 and ASCE/SEI 7-16 standards.
- Level 2 & 3 enclosures include sound attenuation foam
- Level 3 enclosure includes frontal sound & exhaust hood.
- Enclosure height does not include exhaust stack.

	24 Hour 1000 Gallon	48 Hour 2000 Gallon	72 Hour 3000 Gallon
L	160.00	204.00	294.00
H	148.00	158.00	158.00

Notes

- All specification sheet dimensions are represented in inches.
- All drawings based on standard 480 volt standby generator. Lengths may vary with other voltages. All drawings and dimensions subject to change without notice.
- All enclosures and fuel tanks are based on the standard unit configuration. Any requested deviation can change dimensions.
- Sound data is measured at 23 feet (7 meters) in accordance with ISO 8528-10.
- All materials and specifications subject to change without notice.

Blue Star Power Systems

2250 Carlson Drive
North Mankato, Minnesota 56003
Phone + 1 507 345 1776
bluestarps.com
quote.bluestarps.com
sales@bluestarps.com

/ A DEUTZ COMPANY /