

BLUE STAR Power Systems

Gaseous Product Line

208-600 Volt

GM50-03

60 Hz / 1800 RPM

50 kWe

Standby

Ratings

	240V	208V	240V	480V	600V
Phase	1	3	3	3	3
PF	1	0.8	0.8	0.8	0.8
Hz	60	60	60	60	60
Generator Model	UCI224F	UCI224E	UCI224E	UCI224D	UCI224D
Connection	12 LEAD DD	12 LEAD WYE	12 LEAD DELTA	12 LEAD WYE	4 LEAD WYE
kWe Nat (LP)	50 (50)	50 (50)	50 (50)	50 (50)	50 (50)
AMPS Nat (LP)	208 (208)	174 (174)	151 (151)	75 (75)	60 (60)
Temp Rise	125°C / 40°C	125°C / 40°C	125°C / 40°C	125°C / 40°C	125°C / 40°C

Standard Equipment

Engine

- Radiator Cooled Unit Mounted (50°C)
- Radiator Duct Flange (OPU Only)
- Blower Fan & Fan Drive
- Starter & Alternator
- Oil Pump & Filter
- Oil Drain Extension w/Valve
- Governor - Electronic Isochronous
- 12V Battery System & Cables
- Air Cleaner (Dry Single Stage)
- Critical Grade Silencer Mounted
- Flexible Fuel Connector
- EPA Certified

Generator

- Brushless Single Bearing
- Automatic Voltage Regulator
- ± 1% Voltage Regulation
- 4 Pole, Rotating Field
- 125°C Standby Temperature Rise
- 100% of Rated Load - One Step
- 5% Maximum Harmonic Content
- NEMA MG 1, IEEE and ANSI Standards Compliance for Temperature Rise

Additional

- Single Source Supplier
- UL 2200 & cUL Listed
- CSA Certified
- Seismic Certified to IBC 2021
- NFPA 110 / CSA C282 Compliant
- Microprocessor Based Digital Control Panel Mounted in NEMA 12 Enclosure
- Base - Formed Steel
- Main Line Circuit Breaker Mounted & Wired
- Battery Charger 12V 6 Amp
- Jacket Water Heater -20°F 1500W 120V w/Isolation Valves
- Vibration Isolation Mounts
- 2 Year / 2000 Hour Standby Warranty
- Standard Colors - White / Gray

Application Data

Engine

Manufacturer:	Power Solutions International	Displacement - Cu. In. (lit):	350 (5.70)
Model:	5.7L NA	Bore - in. (cm) x Stroke - in. (cm):	4.00 (10.2) x 3.48 (8.84)
Type:	4-Cycle	Compression Ratio:	9.40:1
Aspiration:	Natural	Rated RPM:	1800
Cylinder Arrangement:	8 Cylinder Vee	Max HP Stby (kWm):	113 (84.3)

Exhaust System

	Standby
Gas Temp. (Stack): °F (°C)	1,350 (732)
Gas Volume at Stack Temp: CFM (m ³ /min)	553 (15.7)
Maximum Allowable Exhaust Restriction: in. H ₂ O (kPa)	40.8 (10.2)

Cooling System

Ambient Capacity of Radiator: °F (°C)	122 (50.0)
Maximum Allowable Static Pressure on Rad. Exhaust: in. H ₂ O (kPa)	0.50 (0.12)
Water Pump Flow Rate: GPM (lit/min)	36.6 (139)
Heat Rejection to Coolant: BTUM (kW)	3,120 (54.6)
Heat Rejection to CAC: BTUM (kW)	N/A
Heat Radiated to Ambient: BTUM (kW)	677 (11.9)

Air Requirements

Aspirating: CFM (m ³ /min)	173 (4.90)
Air Flow Required for Rad. Cooled Unit: CFM (m ³ /min)	7,400 (209)
Air Flow Required for Heat Exchanger/Rem. Rad. CFM (m ³ /min)	Consult Factory For Remote Cooled Applications

Fuel Consumption

	Natural Gas	LP
At 100% of Power Rating: ft ³ /hr (m ³ /hr)	736 (20.8)	286 (8.09)
At 75% of Power Rating: ft ³ /hr (m ³ /hr)	592 (16.8)	262 (7.41)
At 50% of Power Rating: ft ³ /hr (m ³ /hr)	465 (13.2)	182 (5.15)
Fuel Inlet Size: NPT		1.00"
Fuel Pressure Required: in. H ₂ O (kPa)		11.0 (2.75)

Fluids Capacity

Total Oil System: gal (lit)	1.25 (4.73)
Engine Jacket Water Capacity: gal (lit)	2.03 (7.68)
System Coolant Capacity: gal (lit)	6.00 (22.7)

All calculations based on natural gas fuel.

Deration Factors: Altitude: Derate 3% Per 1,000 ft Over 4,200 ft

DCP7310 Control Panel

Standard Features

- Digital Metering
- Engine Parameters
- Generator Protection Functions
- Engine Protection
- CAN Bus (J1939) ECU Communications
- Windows-Based Software
- Multilingual Capability
- Remote Communications to DSE2548 Remote Annunciator
- 8 Programmable Contact Inputs
- 10 Contact Outputs
- RS485 Communicator Interface
- cULus Listed, CE Approved
- Event Recording
- IP 65 rating (with supplied gasket) offers increased resistance to water ingress
- NFPA 110 Level 1 Compatible

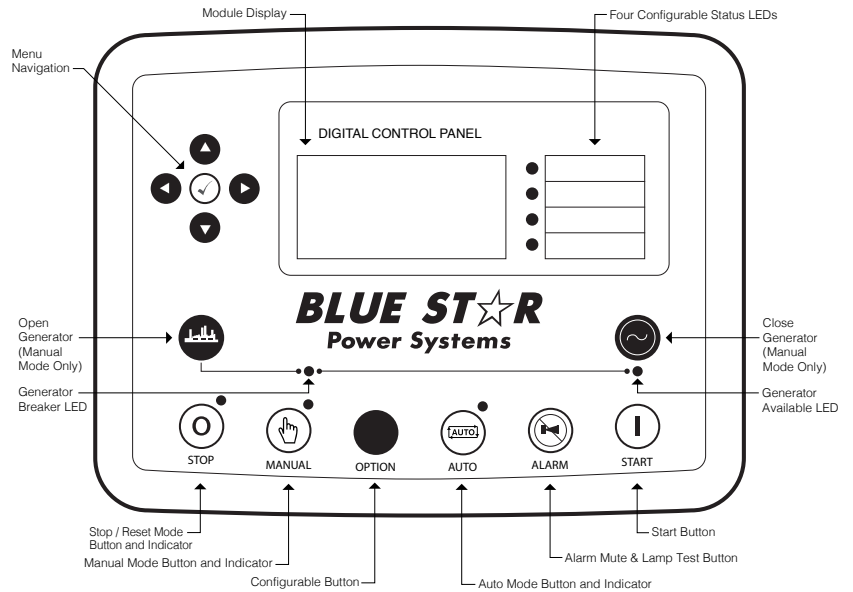

Weights / Dimensions / Sound Data

	L x W x H	Weight lbs
OPU	80 x 38 x 52 in	1,800
Level 1	90 x 38 x 60 in	2,275
Level 2	90 x 38 x 60 in	2,300
Level 3	120 x 38 x 60 in	2,450

Please allow 6-12 inches for height of exhaust stack.

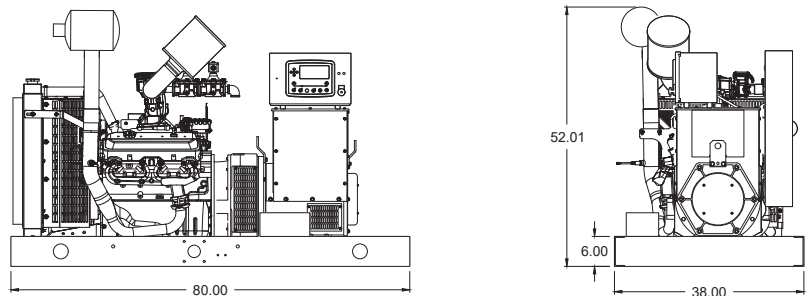
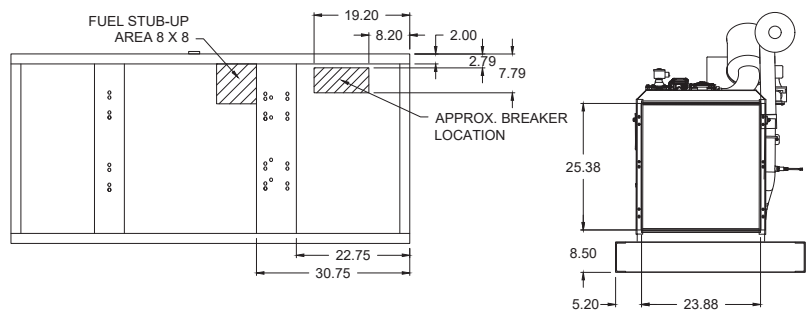

	No Load	Full Load
OPU	76 dBA	79 dBA
Level 1	71 dBA	73 dBA
Level 2	66 dBA	68 dBA
Level 3	63 dBA	64 dBA

Enclosures

Level 1 & 2 | Side View (Weather Proof)

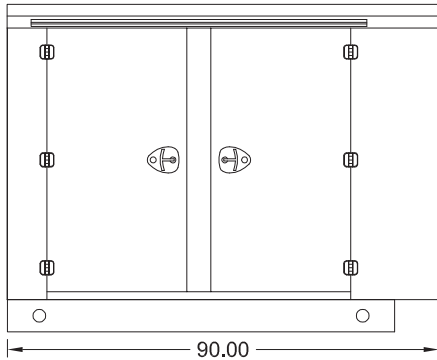

Level 3 | Side View (Sound Attenuated)

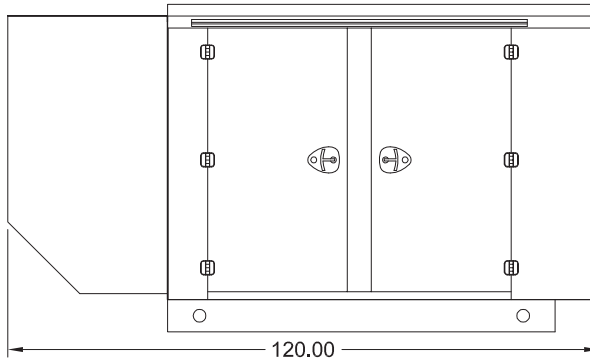

Level 1, 2 & 3 | Intake View

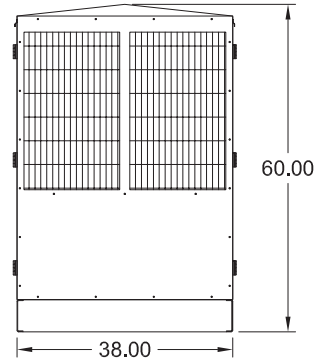

- All enclosure models are 200 MPH wind rating certified in accordance with IBC2021 and ASCE/SEI 7-16 standards.
- Level 2 & 3 enclosures include sound attenuation foam
- Level 3 enclosure includes frontal sound & exhaust hood.
- Enclosure height does not include exhaust stack.

Notes

- All specification sheet dimensions are represented in inches.
- All drawings based on standard 480 volt standby generator. Lengths may vary with other voltages. All drawings and dimensions subject to change without notice.
- All enclosures are based on the standard unit configuration. Any requested deviation can change dimensions.
- Sound data is measured at 23 feet (7 meters) in accordance with ISO 8528-10.
- All materials and specifications subject to change without notice.

Blue Star Power Systems

2250 Carlson Drive
North Mankato, Minnesota 56003

Phone + 1 507 345 1776

bluestarps.com

quote.bluestarps.com

sales@bluestarps.com

/// A DEUTZ COMPANY ///