

BLUE STAR

Power Systems

Gaseous Product Line

480-4160 Volt

NG1250-01

60 Hz / 1800 RPM

1250 kWe

Standby

Ratings

	480V	600V	4160V
Phase	3	3	3
PF	0.8	0.8	0.8
Hz	60	60	60
Generator Model	S6L1D-H	S6L1D-H	MVWI734F
Connection	4 LEAD WYE	4 LEAD WYE	6 LEAD WYE
kWe Nat (LP)	1250 (N/A)	1250 (N/A)	1250 (N/A)
AMPS Nat (LP)	1882 (N/A)	1505 (N/A)	217 (N/A)
Temp Rise	125°C / 40°C	125°C / 40°C	125°C / 40°C

Standard Equipment

Engine

- Radiator Cooled Unit Mounted (50°C)
- Radiator Duct Flange (OPU Only)
- Blower Fan & Fan Drive
- Starter & Alternator
- Oil Pump & Filter
- Oil Drain Extension w/Valve
- Governor - Electronic Isochronous
- 24V Battery System & Cables
- Air Cleaner (Dry Single Stage)
- Catalyst / Silencer Mounted
- Flexible Fuel Connector
- EPA Certified

Generator

- Brushless Single Bearing
- Automatic Voltage Regulator
- ± 0.50% Voltage Regulation
- 4 Pole, Rotating Field
- 125°C Standby Temperature Rise
- 100% of Rated Load - One Step
- 5% Maximum Harmonic Content
- NEMA MG 1, IEEE and ANSI Standards Compliance for Temperature Rise

Additional

- Single Source Supplier
- NFPA 110 / CSA C282 Compliant
- Microprocessor Based Digital Control Panel Mounted in NEMA 12 Enclosure
- Base - Structural Steel
- Main Line Circuit Breaker Mounted & Wired
- Battery Charger 24V 5 Amp
- Jacket Water Heater (Qty 2) -20°F 9000W 240V w/Isolation Valves
- Vibration Isolation Mounts (Pad Type)
- 2 Year / 2000 Hour Standby Warranty
- Standard Colors - White / Gray

Application Data

Engine

Manufacturer:	Power Solutions International	Displacement - Cu. In. (lit):	3192 (52.3)
Model:	53LHO	Bore - in. (cm) x Stroke - in. (cm):	5.91 (15.0) x 7.28 (18.5)
Type:	4-Cycle	Compression Ratio:	10.5 : 1
Aspiration:	Turbo Charged, CAC	Rated RPM:	1800
Cylinder Arrangement:	16 Cylinder Vee	Max HP Stby (kW _m):	1926 (1,437)

Exhaust System

Standby

Gas Temp. (Stack): °F (°C)	1,247 (675)
Gas Volume at Stack Temp: CFM (m ³ /min)	8,403 (238)
Maximum Allowable Exhaust Restriction (Post Catalyst): in. H ₂ O (kPa)	18.7 (4.67)

Cooling System

Ambient Capacity of Radiator: °F (°C)	122 (50.0)
Maximum Allowable Static Pressure on Rad. Exhaust: in. H ₂ O (kPa)	0.50 (0.12)
Water Pump Flow Rate: GPM (lit/min)	601 (2,275)
Heat Rejection to Coolant: BTUM (kW)	58,920 (1,031)
Heat Rejection to CAC: BTUM (kW)	12,041 (211)
Heat Radiated to Ambient: BTUM (kW)	25,314 (443)

Air Requirements

Aspirating: CFM (m ³ /min)	2,653 (75.1)
Air Flow Required for Rad. Cooled Unit: CFM (m ³ /min)	68,000 (1,924)
Air Flow Required for Heat Exchanger/Rem. Rad. CFM (m ³ /min)	Consult Factory For Remote Cooled Applications

Standby

Fuel Consumption

Natural Gas

LP

At 100% of Power Rating: ft ³ /hr (m ³ /hr)	14,022 (397)	N/A
At 75% of Power Rating: ft ³ /hr (m ³ /hr)	10,884 (308)	N/A
At 50% of Power Rating: ft ³ /hr (m ³ /hr)	7,940 (225)	N/A
Fuel Inlet Size: NPT		3.00"
Fuel Pressure Required: in. H ₂ O (kPa)		30.0 (7.50)

Fluids Capacity

Total Oil System: gal (lit)	45.2 (171)
Engine Jacket Water Capacity: gal (lit)	26.4 (100)
System Coolant Capacity: gal (lit)	65.4 (248)

All calculations based on 1,000 BTU/FT³ natural gas fuel.

Deration Factors: Temperature: Derate 0.8% Per 5°F Over 77°F Air Inlet Temperature | Altitude: Derate 2.5% Per 1,000 ft Over 1,200 ft

DCP7310 Control Panel

Standard Features

- Digital Metering
- Engine Parameters
- Generator Protection Functions
- Engine Protection
- CAN Bus (J1939) ECU Communications
- Windows-Based Software
- Multilingual Capability
- Remote Communications to DSE2548 Remote Annunciator
- 8 Programmable Contact Inputs
- 10 Contact Outputs
- RS485 Communicator Interface
- cULus Listed, CE Approved
- Event Recording
- IP 65 rating (with supplied gasket) offers increased resistance to water ingress
- NFPA 110 Level 1 Compatible

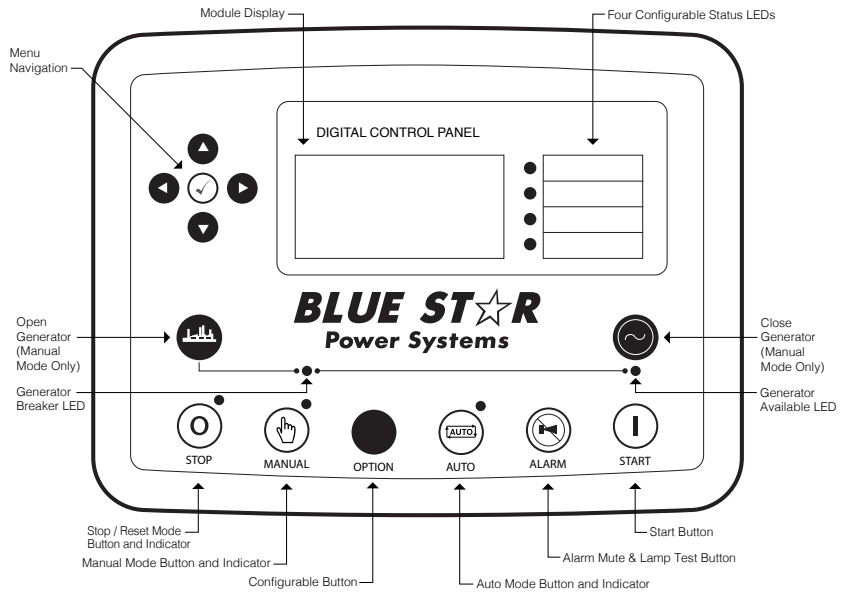

Weights / Dimensions / Sound Data

	L x W x H	Weight lbs
OPU	252 x 106 x 119 in	28,775
Level 1	252 x 106 x 129 in	31,100
Level 2	252x 106 x 129 in	31,325
Level 3	342 x 106 x 129 in	33,975

Please allow 6-12 inches for height of exhaust stack.

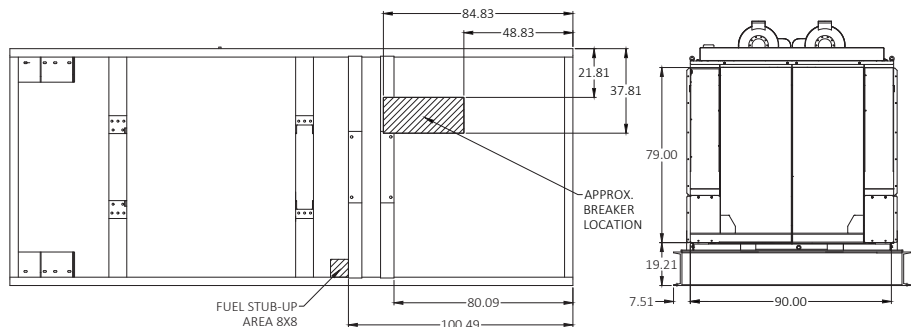

	No Load	Full Load
OPU	90 dBA	93 dBA
Level 1	88 dBA	91 dBA
Level 2	83 dBA	86 dBA
Level 3	78 dBA	81 dBA

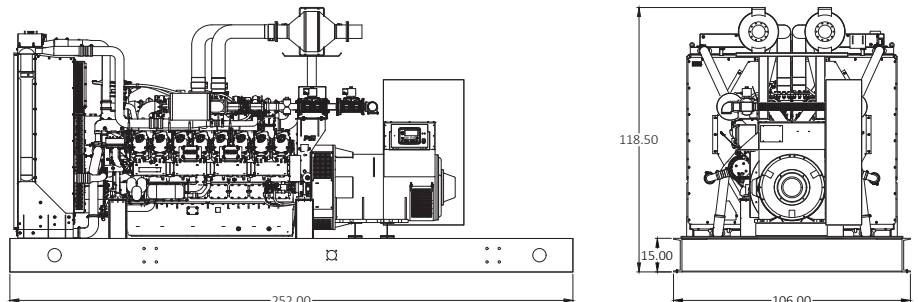

Enclosures

Level 1 & 2 | Side View (Weather Proof)

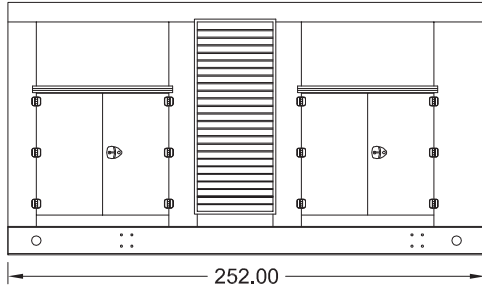

Level 3 | Side View (Sound Attenuated)

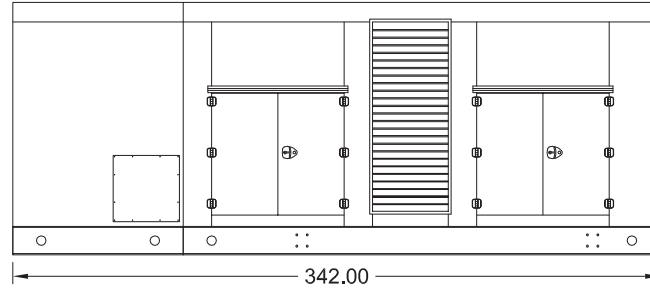

Level 1, 2 & 3 | Intake View

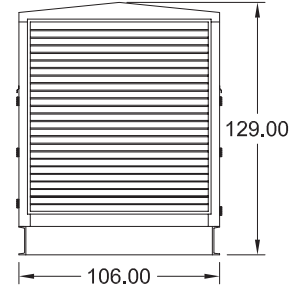

- All enclosure models are 200 MPH wind rating certified in accordance with IBC2021 and ASCE/SEI 7-16 standards.
- Level 2 & 3 enclosures include sound attenuation foam
- Level 3 enclosure includes frontal sound & exhaust hood.
- Enclosure height does not include exhaust stack.

Notes

- All specification sheet dimensions are represented in inches.
- All drawings based on standard 480 volt standby generator. Lengths may vary with other voltages. All drawings and dimensions subject to change without notice.
- All enclosures are based on the standard unit configuration. Any requested deviation can change dimensions.
- Sound data is measured at 23 feet (7 meters) in accordance with ISO 8528-10.
- All materials and specifications subject to change without notice.

Blue Star Power Systems

2250 Carlson Drive
North Mankato, Minnesota 56003
Phone + 1 507 345 1776
bluestarps.com
quote.bluestarps.com
sales@bluestarps.com

/ A DEUTZ COMPANY /