

# BLUE STAR Power Systems

Diesel Product Line

208-480 Volt

JD40-05FT4MP

60 Hz / 1800 RPM

40 kWe / 40 kWe

Standby / Prime

## Ratings

	240V	208V	240V	480V	Multi-Voltage
<b>Phase</b>	1	3	3	3	3 / 1
<b>PF</b>	1	0.8	0.8	0.8	0.8 / 1.0
<b>Hz</b>	60	60	60	60	60
<b>Generator Model</b>	UCI224E	UCI224D	UCI224D	UCI224D	UCI224E
<b>Connection</b>	12 LEAD DD	12 LEAD WYE	12 LEAD DELTA	12 LEAD WYE	12 LEAD CONFIGURABLE
<b>Standby kWe</b>	40	40	40	40	40
<b>AMPS</b>	167	139	120	60	167/139/120/60
<b>Temp Rise</b>	105°C / 40°C	105°C / 40°C	105°C / 40°C	105°C / 40°C	105°C / 40°C
<b>Prime kWe</b>	40	40	40	40	40
<b>AMPS</b>	167	139	120	60	167/139/120/60
<b>Temp Rise</b>	105°C / 40°C	105°C / 40°C	105°C / 40°C	105°C / 40°C	105°C / 40°C

## Standard Equipment

### Engine

- Radiator Cooled Unit Mounted (50°C)
- Radiator Duct Flange (OPU Only)
- Blower Fan & Fan Drive
- Starter & Alternator
- Oil Pump & Filter
- Oil Drain Extension w/Valve
- Governor - Electronic Isochronous
- 12V Battery System & Cables
- Air Cleaner (Dry Single Stage)
- Exhaust Filter / Silencer Mounted
- Flexible Fuel Connector
- EPA Certified Tier 4 Final

### Generator

- Brushless Single Bearing
- Automatic Voltage Regulator
- ± 1% Voltage Regulation
- 4 Pole, Rotating Field
- 105°C Standby Temperature Rise
- 105°C Prime Temperature Rise
- 100% of Rated Load - One Step
- 5% Maximum Harmonic Content
- NEMA MG 1, IEEE and ANSI Standards Compliance for Temperature Rise

### Additional

- Single Source Supplier
- NFPA 110 / CSA C282 Compliant
- Microprocessor Based Digital Control Panel Mounted in NEMA 12 Enclosure
- Base - Formed Steel
- Level 3 Sound Attenuated Enclosure
- Trailer with Integrated 130 Gallon Fuel Tank
- Main Line Circuit Breaker Mounted & Wired
- Battery Charger 12V 6 Amp
- Jacket Water Heater -20°F 1000W 120V w/Isolation Valves
- Vibration Isolation Mounts
- 2 Year / 2000 Hour Standby Warranty
- 1 Year / 1500 Hour Prime Warranty
- Standard Color - White

## Application Data

### Engine

Manufacturer:	John Deere	Displacement - Cu. In. (lit):	177 (2.90)
Model:	3029HG530	Bore - in. (cm) x Stroke - in. (cm):	4.20 (10.7) x 4.30 (11.0)
Type:	4-Cycle	Compression Ratio:	16.9:1
Aspiration:	Turbo Charged, CAC	Rated RPM:	1800
Cylinder Arrangement:	3 Cylinder Inline	Max HP Stby (kW <sub>m</sub> ):	74.0 (55.2)

### Exhaust System

	Standby	Prime
Gas Temp. (Stack): °F (°C)	932 (500)	932 (500)
Gas Volume at Stack Temp: CFM (m <sup>3</sup> /min)	456 (12.9)	456 (12.9)
Maximum Allowable Exhaust Restriction (Post Catalyst): in. H <sub>2</sub> O (kPa)	20.0 (5.00)	20.0 (5.00)

### Cooling System

Ambient Capacity of Radiator: °F (°C)	122 (50.0)	122 (50.0)
Maximum Allowable Static Pressure on Rad. Exhaust: in. H <sub>2</sub> O (kPa)	0.50 (0.12)	0.50 (0.12)
Water Pump Flow Rate: GPM (lit/min)	26.0 (98.4)	26.0 (98.4)
Heat Rejection to Coolant: BTUM (kW)	1,618 (28.3)	1,618 (28.3)
Heat Rejection to CAC: BTUM (kW)	620 (10.9)	620 (10.9)
Heat Radiated to Ambient: BTUM (kW)	855 (15.0)	855 (15.0)

### Air Requirements

Aspirating: CFM (m <sup>3</sup> /min)	177 (5.01)	177 (5.01)
Air Flow Required for Rad. Cooled Unit: CFM (m <sup>3</sup> /min)	6,714 (190)	6,714 (190)
Air Flow Required for Heat Exchanger/Rem. Rad. CFM (m <sup>3</sup> /min)	Consult Factory For Remote Cooled Applications	

### Fuel Consumption

At 100% of Power Rating: gal/hr (lit/hr)	3.54 (13.4)	3.54 (13.4)
At 75% of Power Rating: gal/hr (lit/hr)	2.74 (10.4)	2.74 (10.4)
At 50% of Power Rating: gal/hr (lit/hr)	2.04 (7.72)	2.04 (7.72)

### Fluids Capacity

Total Oil System: gal (lit)	2.25 (8.50)	2.25 (8.50)
Engine Jacket Water Capacity: gal (lit)	1.32 (5.00)	1.32 (5.00)
System Coolant Capacity: gal (lit)	4.62 (17.5)	4.62 (17.5)

Deration Factors: Rated Power is available up to 8,000 Ft (2438m) at ambient temperatures to 122°F (50°C). Consult factory for site conditions above these parameters.

## DCP7310 Control Panel

### Standard Features

- Digital Metering
- Engine Parameters
- Generator Protection Functions
- Engine Protection
- CAN Bus (J1939) ECU Communications
- Windows-Based Software
- Multilingual Capability
- Remote Communications to DSE2548 Remote Annunciator
- 8 Programmable Contact Inputs
- 10 Contact Outputs
- RS485 Communicator Interface
- cULus Listed, CE Approved
- Event Recording
- IP 65 rating (with supplied gasket) offers increased resistance to water ingress
- NFPA 110 Level 1 Compatible

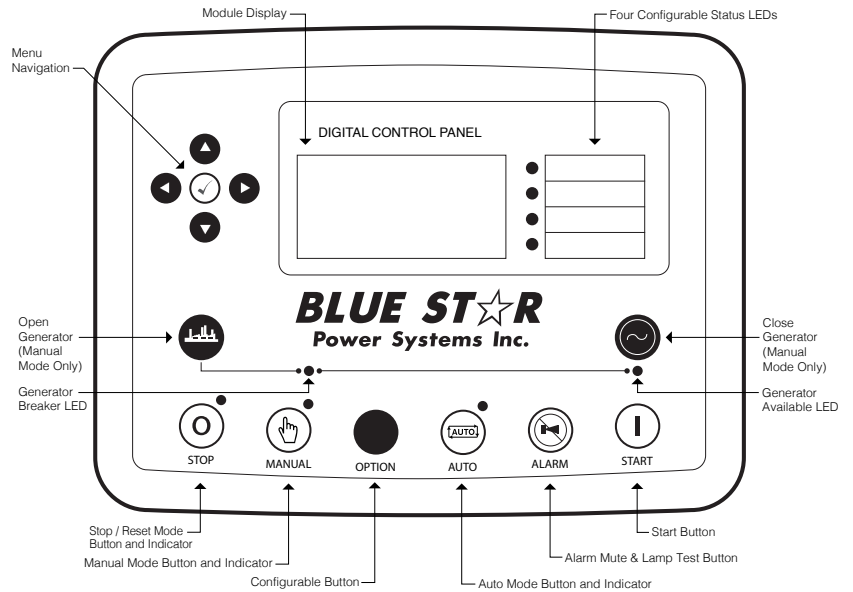

## Convenience Panel

- 2-50A 125/250VAC 3P4W Twist Lock Non-Nema CS6369
- 1-30A 125/250VAC 3P4W Twist Lock Nema L14-30R
- 2-20A 120VAC Duplex GFCI Nema 5-20R
- Thumb Screw Terminals for 2-Wire Remote Start
- 15A 120VAC Male Receptacle for Jacket Water Heater and Battery Charger Shore Power Connection
- 5-400A Rated Female Cam Style Locking Receptacles for Load Connection

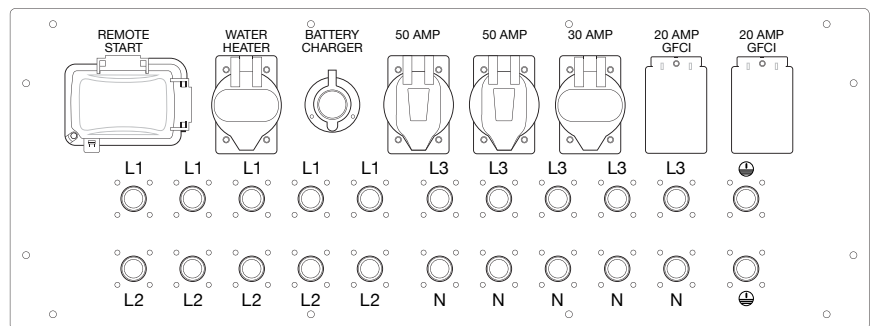

\* Drawing and configuration may vary from illustration. All drawings and dimensions subject to change without notice.

Dimensions

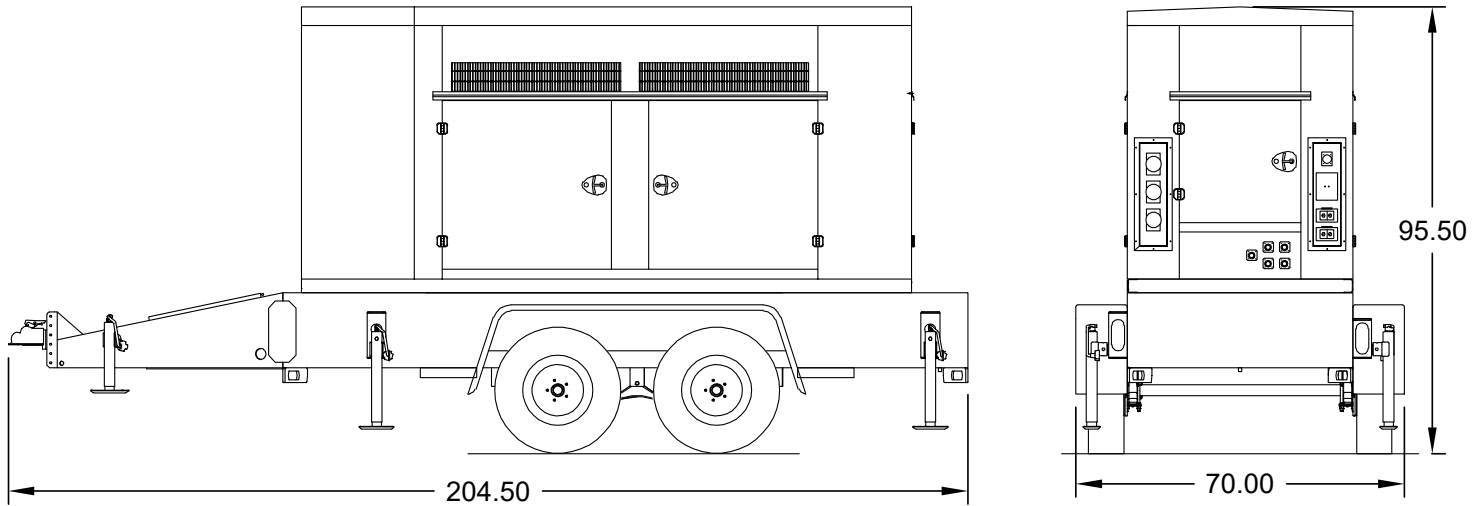

- Approximate Ship Weight: 7,500 lbs.
- Approximate Wet Weight: 8,450 lbs.
- Weights based on standard trailer package. Additional options may increase weight.
- Sound data measured at 23 feet (7 meters) in accordance with ISO 8528-10.

	No Load	Full Load
Sound Data	60 dBA	62 dBA

Notes

- All specification sheet dimensions are represented in inches.
- All drawings based on standard 480 volt standby generator. Lengths may vary with other voltages. All drawings and dimensions subject to change without notice.
- All enclosures and fuel tanks are based on the standard standby unit configuration. Any deviation can change dimensions.
- Sound data is measured at 23 feet (7 meters) in accordance with ISO 8528-10.
- All materials and specifications subject to change without notice.

**Blue Star Power Systems**

2250 Carlson Drive  
North Mankato, Minnesota 56003  
Phone + 1 507 345 1776  
bluestarps.com  
quote.bluestarps.com  
sales@bluestarps.com

**/// A DEUTZ COMPANY ///**