

# DGC-2020 Control Panel



Blue Star Power Systems Digital Generator Set Control Panel (DGC-2020) is a highly advanced integrated generator set control system. The DGC-2020 is perfectly focused, combining rugged construction and microprocessor technology to offer a product that will hold up to almost any environment and flexible enough to meet your application's needs. This device provides generator set control, transfer switch control, metering, protection and programmable logic in a simple, easy to use, reliable, rugged, and cost effective package.

## Highlights

- UL Recognized, CSA & CE approved
- Microprocessor based
- Complete system metering
- Remote communication options
- Rugged encapsulated construction

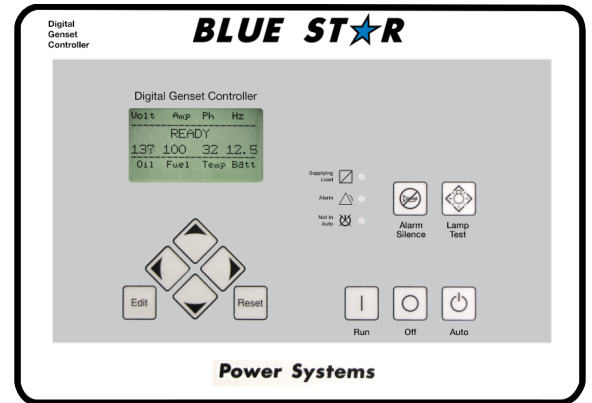

## Standard Features

- Generator Metering
- Engine Metering
- Generator Set Control
- Engine Protection:
  - Oil Pressure
  - Engine Temperature
  - Overspeed
  - Overcrank
- BESTCOMS Plus:
  - Programming and Setup Software
  - Intuitive and Powerful
  - Remote Control and Monitoring
  - Programmable Logic
  - USB Communications
- SAE J1939 Engine ECU Communications (Where Applicable)
- Extremely Rugged, Fully Encapsulated Design
- 16 Programmable Inputs
- 7 Contact Outputs: (3) 30ADC and (4) Programmable 2ADC Rated Contacts
- Wide Ambient Temperature Range
- UL Recognized, CSA Certified, CE Approved
- HALT (Highly Accelerated Life Test) Tested
- IP54 Front Panel Rating with Integrated Gasket
- NFPA110 Level One Compliant
- Real Time Clock with Battery Backup and Event Log
- Emergency Stop Pushbutton
- Current Sensing: 5A CT inputs
- Generator Frequency: 50/60 Hz
- LCD Display Heater to -40°F
- Event Recording (up to 99 occurrences)

## Standard Gen-Set Monitoring

- Generator parameters: voltage, current, frequency, real power (Watts), apparent power (VA), and power factor
- Engine parameters: oil pressure, coolant temperature, RPM, battery voltage, fuel level, engine runtime, and various J1939 supported parameters where applicable

## Standard Engine Control Functions

### Cranking Control

- Cyclic or Continuous (Fully Programmable)

### Successful Start Counter

- Counts and Records Successful Engine Starts

### Timers

- Engine Cooldown Timer (Specify)
- Engine Maintenance Interval Timer (Specify)
- Pre-Alarm Time Delays for Weak/Low Battery Voltage
- Alarm Time Delay for Overspeed

- Alarm Time Delay for Sender Failure
- Arming Time Delays After Crank Disconnect:
  - Low Oil Pressure
  - High Coolant Temperature
  - Pre-Crank Delay
- Continuous/Cyclic Cranking Timing Sequence

## Front Panel LED Indicators:

- **Run: Green** – Indicates controller is in the RUN mode
- **Off: Red** – Indicates controller is in the OFF mode
- **Auto: Green** – Indicates unit is in the AUTO mode
- **Not in Auto: Red** – Indicates DGC-2020 is not in AUTO mode
- **Supplying Load: Green** – Indicates system is supplying current to a connected load
- **Alarm: Red** – Indicates an alarm situation by continuous illumination  
*A pre-alarm will flash*

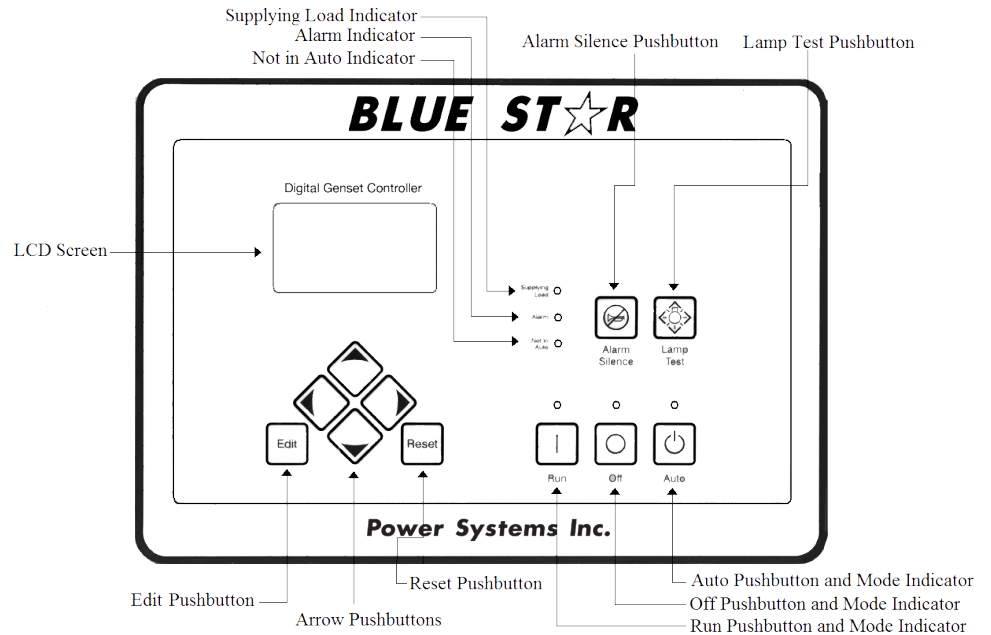

## Standard Engine Protection Functions

### Pre-Alarms (Warnings)

- Low Oil Pressure
- High Coolant Temperature
- Low Coolant Temperature
- Battery Overcharge (High Voltage)
- Weak Battery (Low Voltage)

- Battery Charger Failure
- Engine Sender Unit Failure
- Engine kWe Overload
- Maintenance Interval Timer
- Low Fuel Level
- Fuel Leak Detect

### Alarms (Shutdowns)

- Low Oil Pressure
- High Coolant Temperature
- Overspeed
- Overcrank
- Fuel Sender Failure

- All alarms and pre-alarms can be configured via the BESTCOMSPiUS PC software or the front panel.

## Optional Features

- Generator Protection 27(2), 32, 40Q, 51(2), 59(2), 81O, 81U
- Enhanced Generator Protection - 51 and 47
- Selection of Integrating Reset or Instantaneous Reset Characteristics for Overcurrent Protection
- Remote Communication to RDP-110 / NFPA-110 Compliant Remote Annunciator
- Additional (8) Programmable 2ADC Contacts
- Remote Dial-out and Dial-in Capability with Modem
- Modbus Communications with RS-485
- Expandable I/O Capability via J1939 CANBUS
- Automatic Transfer Switch Control
- Remote Emergency Stop
- Multilingual Capability
- High Fuel Level Pre-Alarm
- Critical Low Fuel Level Alarm
- Analog Meters

## Generator Protection

- Undervoltage (27)
- Underfrequency (81U)
- Overcurrent (51)
- Reverse Power (32)
- Phase Imbalance (47)
- Overvoltage (59)
- Overfrequency (81O)
- Phase Imbalance (57)
- Loss of Excitation (400)
- Generator Overcurrent (51)

All generator protection features are programmable as alarms or pre-alarms.

## Contact Outputs

For those applications where more output contacts are needed, the DGC-2020 can be adapted to include 8 additional 2ADC rated dry contact outputs. These are real contacts and not the solid-state type that require additional external circuitry to properly operate. These contacts are fully programmable via the easy-to-use BESTCOMSPlus PC software and can be assigned to numerous user-defined functions.

## DC Voltage Panel Mounted Modem

The DGC-2020 can provide long distance communication by adding a modem. When a modem is used, the user can access the DGC-2020 from virtually anywhere via a dedicated telephone line. The user can monitor and control the gen-set as if standing right in front of it. The DGC-2020 can also dial out for pre-programmed circumstances to alert the user of selected situations.

## RS-485 Communication

When the RS-485 option is selected, the user can send and receive information from the DGC-2020 via the RS-485 communications port and Modbus protocol. This feature allows the DGC-2020 to be fully integrated into the building management system. Please see the instruction manual for the Modbus register list.

## Enhanced Generator Protection

In addition to the standard generator protection (27, 59, 81O, 81U) the DGC-2020 can be equipped with a more sophisticated generator protection system. This option provides an overcurrent element (51) with 17 selectable time current characteristic curves and a voltage phase balance protection function.

## Transfer Switch Control (Mains Failure)

The DGC-2020 monitors utility (mains) and determines if it is providing power that is suitable for the loads. If the utility supply goes outside of predetermined levels, the generator is started and the utility is disconnected from the load and the generator is connected. When the utility returns to acceptable levels for a sufficient time, the generator is disconnected and the utility is reconnected to the load. It also includes appropriate adjustable timers or time delays for establishing stable utility operation.

## Contact Expansion Module (CEM)

The CEM add-on module increases the contact input and contact output capability adding 10 contact inputs and 24 form C contact outputs. This module communicates to the DGC-2020 via SAE J1939 CANBUS and allows the user to program the functionality of these inputs and outputs in the BESTCOMS programmable logic program. The user can add labels for the inputs and outputs that appear on BESTCOMS front panel, and in the programmable logic. All the functionality can be assigned to these inputs and outputs as if they were an integrated part of the DGC-2020. The CEM-2020 module has all of the environmental ratings, like the DGC-2020, including a model for UL Class1 Div2 applications (consult price list for part number). The output ratings of the form C contacts are: (12 contacts) 10A @ 30VDC and (12 contacts) 2A @ 30VDC. The 2A rated contacts are gold flash contacts for low current circuits. The CEM-2020 terminals accept a maximum wire size of 12 AWG while the chassis ground requires 12 AWG wire. The CEM-2020 provides the user with the flexibility to use the same model DGC-2020 gen-set controller for simple applications or more complicated applications that require contact functionality or duplication of contacts for remote annunciation. Flexibility is one of the benefits of the DGC-2020, and this add-on module enhances that benefit even further.

## ModBus TCP/RTU (NetBiter RTU-TCP Gateway)

NetBiter® RTU-TCP Gateway connects the fully enhanced DGC-2020 with Ethernet and mobile networks. The gateway acts as a transparent bridge translating DGC-2020 Modbus registers allowing control systems, such as PLCs, SCADA, etc. to communicate over Ethernet. One gateway is required per generator allowing multiple generator sets to be accessed and monitored simultaneously. Note: This option does not interface with BESTCOMSPlus software. Features include: connectivity between serial Modbus devices and the Modbus TCP; RS-232, RS-485 and RS-422 connectivity; Ethernet and mobile network connectivity; 10/100 Mbit/s Ethernet; web-based configuration; DIN rail mounting; and network and serial status indicators.

## Load Share Module 2020 (LSM-2020)

The LSM is an easy to connect and use add-on module for the DGC-2020 to allow the DGC-2020 to control the kW load sharing of multiple generator sets. The LSM-2020 is remotely mounted and communicates to the DGC-2020 via J1939 CANbus communications.